

# MERUGE DOC Douro WHITE 2019

*This Meruge White wine is made from a combination of several traditional Douro grape varieties sourced from our families' Douro vineyards, located in our highest plots, with cooler temperatures that provide ideal conditions for making white wine.*



## Characteristics of the Vintage

2018/2019 was a dry year, characterized by large variations in annual temperature and rainfall standards. The climatic conditions led, at an early stage, to a slight advance of the vegetative cycle in relation to the average of the last 5 years. Winter and spring were dry and in the second half of the summer the vineyards needed water to ensure maturations. Fortunately, the lack of rain between May and August was filled by more moderate summer temperatures.

The harvest began in the beginning of September and lasted until mid-October making it one of the longest of the past years. In the mid-September, a couple of days of rainfall came in the right time to help reaching perfect maturation. The harvest provided high quality musts, with higher acidity, great freshness, lower alcohol and a good level of phenolic compounds.

## Viticulture

<b>Grape varieties</b> – 100% Viosinho Roriz	<b>Production method</b> – Integrated production
<b>Soil Type</b> – Schist	<b>Age of vines</b> - Over 45 years old
<b>Vines Altitude</b> – 500m, East exposure	<b>Sub-region</b> – Cima Corgo, São João da Pesqueira

## Vinification

Fermentation in Portuguese oak barrels without toast, and ageing in new Portuguese oak barrels for 6 months.

## Wine analyses

Alcohol: 13,5%  
Total sugar: 0,9 gr/dm<sup>3</sup>  
Total Acidity: 6,5 gr/dm<sup>3</sup>  
pH: 3.30

## Tasting Note

Beautiful citrus straw color. Very elegant nose, fine, full and complex, excellent freshness, with notes of pear, quince and nuances of vanilla. With the wood very well integrated, as it opens in the glass, aromas of spices and dry fruits are released, which make it very rich and quite interesting.

In the mouth is very tasty. The first sensation is freshness, fruity and balanced, evolving to more complex flavors of dried fruits and some vanilla, fruit of its aging in wood. It is expressive and harmonious, has a good balance between structure and acidity, which provides it with longevity.

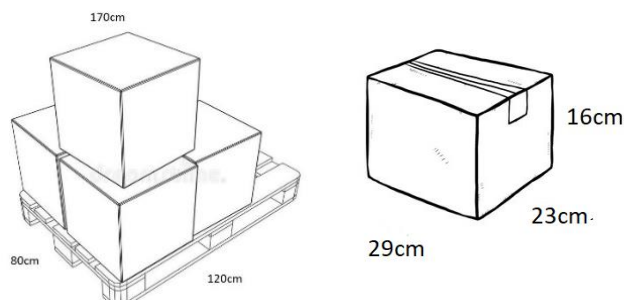

**lavradores de feitoria**